

SERVICE MANUAL



Technical Data

Mechanical Repair

Electrical Repairs

Calibration

Fault Diagnosis

Tools and Test Equipment

Parts List

Continuous operation, with intermittent use.

Electronic system is set to hold a minimum 121°C for 16 minutes (except 210006), 126°C for 11 minutes or 134°C for 3.5 minutes when loaded with instruments.

On model 210006 the electronic system is set to hold 121 °C minimum, for 18 minutes when loaded with instruments.

All sterilizing times incorporate a safety margin between 0.5 and 1 minute depending on the operating temperature.

Nominal operating pressures are 1.05 Bar (15 psi) at 121°C, 1.6 BAR (23psi) at 126°C, and 2.2 BAR (32 psi) at 134°C.

Minimum vessel burst pressure is 7.8 Bar (115 psi).

Safety features

- Pressure release valve
- lid pressure interlock
- Gasket offset device (prevents pressure build up if lid not closed correctly)
- Body thermal fuse
- Boil dry detector
- Gasket extrusion slot for pressure relief
- End of cycle buzzer.
- Bi-metallic air bleed device fitted.

Pressure and temperature gauges available on some models (refer to price list).

Depressurization Valve Kit (RPI Part #KVK043) (OEM Part #219711)

Fig 1.



Circlip in valve handle.

To replace the circlip, remove the decal and push up the valve stem. The circlip may now be removed / replaced

To replace this valve, remove lock nut from inside the lid with a 13mm spanner and lift out complete valve (Fig.1). Replace the valve with new one. Ensure cutouts in the aluminium valve body fit into notches on top handle.

Always replace the seal when refitting the valve. These locate the valve in position.

Tighten nut to 10Nm.

PRESSURE INDICATOR:

To remove this indicator, locate M16 hexagonal nut in a socket and use the specified tool to undo the red cap.

(For tool kit see 6: Tools and Test Equipment).

GASKET OFFSET DEVICE:

The gasket offset device (GOD spring) is a very important safety device. It ensures that if the lid is incorrectly fitted pressure cannot build up. The spring is forced away from the gasket by the body lug as the lid is rotated. The spring allows the gasket to seal when the lid and body lugs are in a half lug engagement or better interlock position.

Gasket Offset Device Cover (RPI Part #KVC019) (OEM Part #219577)

This device must be inspected monthly

To work correctly the spring must be firmly riveted to the lid. It must protrude on the inside of the lid, past the flange by a minimum of 1mm (with gasket removed). See figures 3 and 4.

A new spring cannot be fitted without the correct factory equipment, spring and riveter.

If the spring or rivet is damaged a new lid must be fitted.

Procedure to correct GOD Spring setting

If the limits are outside the specification, then the GOD spring has to be adjusted using long nose pliers.

Fig 2.

Twist Pliers

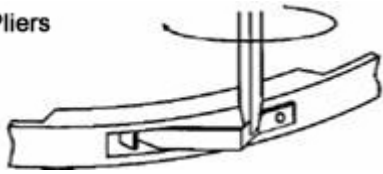
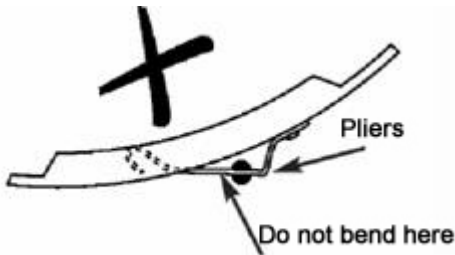

Fig 3.



Ensure the lid is flat and stable and apply the pliers vertically. Locate the pliers onto the back edge of the spring and twist inwards carefully. Do not buckle the spring. Check visually and measure the distance again.

Fig 4.



Remove the lid and gasket to ensure that the spring is protruding from the edge of the flange by 1 mm. (Fig. 5.).

Fig 5.

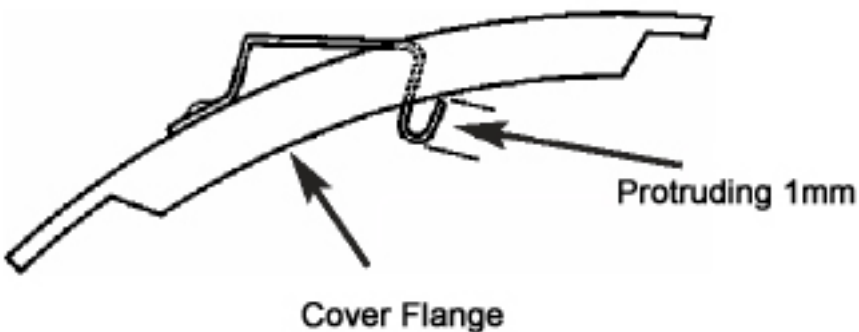

SIDE HANDLES, TOP HANDLE and STEAM DUCT:

Side handles are held in place by M5 securing screws.

To remove the top handle, first remove the steam release valve as previously described, (Fig 1.)

Unscrew the side handles.

Once the top handle is removed the steam duct can be removed by releasing the two retaining pins.

After removal the steam duct will need to be replaced with a new one. Insert the two pins into the appropriate holes in the lid and secure in place by melting the ends using the tip of a hot soldering iron, ensuring that the pins cannot pass back through the holes.

Replace new side handles and top handle following the reverse of the sequence previously described.

New seals must always be used when refitting the top handle, steam duct and steam valve.

Handle (RPI Part #KVH034) (OEM Part #219696)

Handle Moulding (RPI Part #KVH035) (OEM Part #219698)

AIR BLEED DEVICE:

To remove, first take off steam release valve and top handle as previously described (on the 210134 and 210006 you need to remove the steam duct as well). Break off retaining clip and throw away old assembly. (Never re-use assemblies). Fit new air bleed device with 'O' ring, push into lid hole, place washer over valve stem and force 'push fix' down to lock the device in position. Use special tool to push clip over air bleed device spigot.

(For tool kit see 6: Tools and Test Equipment).

Air Bleed Kit (RPI Part #KVK002) (OEM Part #219202)

LID GASKET:

Simply extract the old gasket from the lid flanges and replace with a new one.

Only genuine Prestige Medical parts to be fitted.

Note: No lubrication is required for the gasket.

However, if the lid is difficult to put on, Vaseline (petroleum jelly) can be lightly smeared around the edge and underside of the body flanges.

Door Gasket (RPI Part #KVG001) (OEM Part #219500)

BASE MOULDING:

Place body on a flat surface upside down. Then remove the three 'posi' screws, which hold the electronic module in place

Lift out heatsink to remove module from base moulding. Disconnect the display ribbon cable connector.

Next, remove the earth wires from the body stud, then loosen the nut for the thermistor wire clamp (All M5 size).

Fig 6.

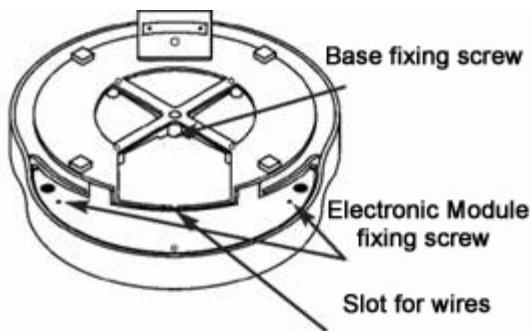

Disconnect the push on terminals from the wiring of the base and the heater element.

The electronic module is now free (Do not remove the thermistor fixing nuts).

Next, remove the fixing screw M5, in the centre of the base moulding and pull off the base moulding complete whilst feeding the module between the moulded support legs.

Replace the base moulding with a new one in reverse order. **DO NOT OVER TIGHTEN SCREW (2.5Nm torque)**. Check to ensure the silicone caps are in position

Make sure no wires are trapped between the base and the body.

Ensure the thermal fuse is in contact with the base, making sure the white putty supporting the thermal fuse is replaced 1

Refitting is in reverse order of the above. The M5 nuts should be tightened to 1 .4Nm. Note:

1. Each earth wire must be fixed to the body stud with a nut (2 wires and 2 nuts).
2. An earth insulation test must also be carried out
3. Apply new feet if necessary.
4. Do not forget to transfer the rating plate.
5. Ensure that the wires between rear mains inlet and module are retained in the location slots provided.
6. Always check that the push on connectors are tight and do not show signs of overheating.

THERMAL FUSES:

The thermal fuse is in the base moulding, to gain access to this part, remove the base as previously described.

The thermal fuse is in the brown wire and must be replaced as a complete assembly with wires and terminals (Fig 7).

Do not replace the fuse only, as this cannot be reconnected to the brown wires without a proper crimping tool.

Fig 7.

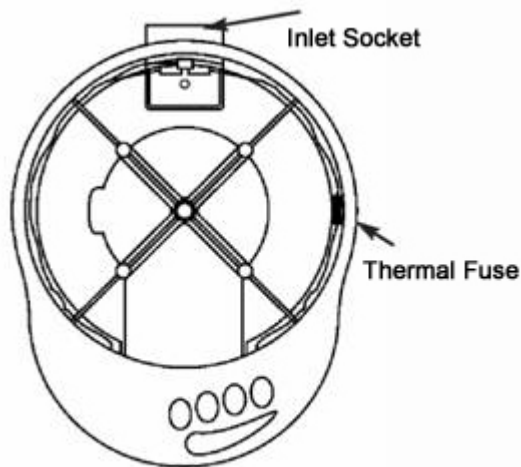
Thermal Fuse (RPI Part #KVF029) (OEM Part #219667)**MAINS INPUT SOCKET:**

Remove base as previously described and remove push on terminals from input socket (Fig.7).

Remove fixing screws from the socket.

Fit new socket and refit base in reverse order.

Always check that the push on connectors are tight and do not show signs of overheating.

ELECTRONIC CONTROL (COMPLETE):

Place body on a flat surface upside down. Then remove the three posi screws, which hold the electronic module in place

Lift up the control module (complete) and disconnect the push on terminals from the wiring of the base and element (as previously described).

Disconnect display ribbon cable. Remove thermistor wire cleat. Remove 2 x M5 nuts on earth stud.

Remove both M5 thermistor pocket retaining nuts. Control module may now be removed.

Note:

1. Clean away all the silicone heat sink compound.
2. When refitting thermistor pocket, apply compound to base of the body centrally between studs (small quantity of compound - 3mm bead size).
Mazak pocket must be pushed towards element. Excess compound must not touch the element - See Fig 8.

Fig 8.

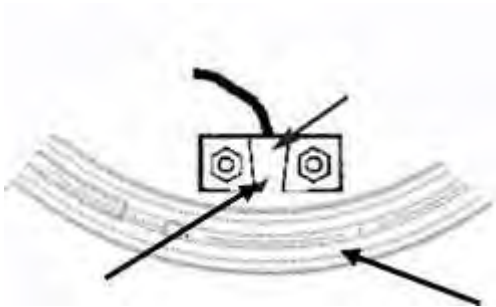

Position Thermistor pocket to create gap - min 0.5 mm; max 1 mm - between pocket & element

3. Refit module in reverse sequence for removal including replacement of white putty under the thermal fuse.
4. The tightening torque for M5 studs is 1.4Nm.
5. After calibration fit new decal.
6. Always check that the push on connectors are tight and do not show signs of overheating.

LED Switch BOARD:

Follow directions for removing Electronic control as per 'base moulding removal'.

Remove the three 'pozi' screws, disconnect the ribbon cable and take the LED Switch board out.

LED/Switch Assembly (RPI Part #KVA024) (OEM Part #219585)

Module Kit (110 VAC) (RPI Part #KVK025) (OEM Part #219590)

PRESSURE GAUGE & TEMPERATURE GAUGE:

To replace a damaged or faulty pressure gauge, the 1/4 BSP nut must be removed.

To replace a damaged or faulty temperature gauge the 3/8 BSP nut must be removed.

The gauge to lid seal is provided by a knife edge machined onto the gauge boss. On a stainless steel lid an aluminium washer is required to complete the seal

The lid must be inspected to ensure there is no damage in this area.

There should be an unbroken indented ring around the hole.

Care must be taken to ensure the knife edge seat on the replacement gauge is not damaged. On stainless steel lids always replace the aluminium washer when replacing a gauge. The gauges must be correctly orientated (nuts to be re-tightened to 35Nm.)

Note: Entry port may be removed by undoing the locknut. Ensure knife edge seal is not damaged and that there is a continuous seal indent in the lid.

THERMOCOUPLE ENTRY PORT (1/4 BSP):

This device consists of connector body, locknut (25mm across flats) and a 3/8 BSP plug (fitted with an 'O' ring.)

This assembly utilises a knife edge seal to lid.

The purpose of the entry port is to enable a qualified engineer to fit a thermocouple pressure probe to check the calibration of the autoclave.

Thermo Port (RPI Part #KVP048) (OEM Part #219750)

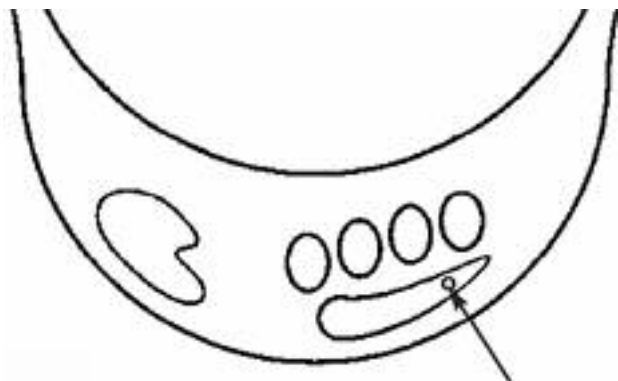
Fig 9.

Fill to water level with **de-ionised/distilled** water (0.75L). Put on the test lid with pressure gauge and digital thermometer connected. Then open the vent valve.

Place the furniture appropriate for the model in the chamber.

Press start button.

Note: Pressing the Start Button when the Yellow sterilizing light is illuminated will automatically set the electronic timer to zero and re-start the sterilizing cycle timer.

Orange heating light should be on.

When temperature of 105°C is reached, close valve.

After about 10 minutes from the start time, the sterilizing light should be lit with the heating light pulsing.

When the sterilizing light has been on for 5 minutes the temperature should be stabilised at between:-

121°C Autoclave 125.5°C to 126.5°C

126°C Autoclave 128.0°C to 129.0°C

134°C Autoclave 136.0°C to 137.0°C

Note: On the 134°C autoclave it will be necessary to press the start button after 2 minutes to reset the sterilizing timer.

If this temperature is too low, turn the pot trimmer clockwise one click at a time to increase the temperature by 0.5 to 1.0°C, allow 1 to 2 minutes for the temperature to stabilise on thermometer.

Press start button after each adjustment to reset timer.

If the temperature is too high, turn the pot trimmer anti-clockwise one click at a time, open the steam release valve for 1 to 2 seconds to drop the temperature quickly.

Note: It is important that the temperature is dropped below target value before vent valve is closed.

When the temperature is stable, switch off and vent with the steam release valve for 1.5 minutes until the temperature is 105°C to 110°C, close the valve and switch on and start another cycle.

FINAL TEST FROM COLD:

Check water level, put furniture in the chamber together with a sterile indication (T. S.T) strip.

Fit product lid, close vent valve and start a cycle. Check the heating light, note the cycle time

(3.5 minutes, 11 minutes, 16 minutes or 18 minutes minimum depending on sterilizing temperature – see page 2 for details).

Check that the sterilizing light goes out after cycle complete light comes on.





Buzzer should sound when the cycle ends.

When cooled down, check the TST indicator strip has changed from yellow to purple/blue.

Note:

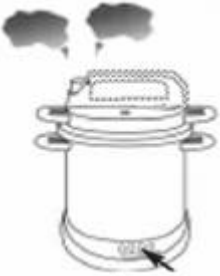
1. If the autoclave is in an ambient temperature of 0°C or less, it will not start a heating cycle. In the event of this occurring, warm up autoclave by moving to another room or add hot water.

(Don't forget to empty and refill with **de-onised / distilled** water).

	<p>Steam or water leaking from the lid of the unit</p>	<p>Worn or dirty gasket Incorrectly fitted lid</p>	<p>Wash gasket - replace in lid If fault persists, replace with new gasket RPI Part #KVG001 Remove lid RPI Part #KVL046 and replace correctly</p>
	<p>Excessive steam or water leaking from the depressurization valve</p>	<p>Valve in open position Worn spring in valve Blown Fuse Defective Socket</p>	<p>Close valve Replace Valve RPI Part #KVK043 Check/Replace Fuse RPI Part #KVF029 Check power to Socket RPI Part #RPR710 Ensure Lead Connected</p>
	<p>TST Strip not changing color.</p>	<p>Unsatisfactory Cycle.</p>	<p>Check expiry date on TST Strip Box OEM Part # 259277 Disconnect from Mains. ReConnect & Repeat Cycle. If still unsatisfactory arrange service.</p>
	<p>Red Fault Light Flashes</p>	<p>Insufficient Water.</p>	<p>Allow unit to cool & refill to correct level. Disconnect from mains. Reconnect & repeat cycle. If the water level is okay disconnect from mains, reconnect & repeat cycle. If still unsatisfactory arrange service</p>
	<p>Green sterilization light fails to illuminate</p>		<p>Disconnect from mains, reconnect & repeat cycle. If still unsatisfactory arrange service</p>

The following tools will be required in servicing/repairing the autoclave:

STANDARD TOOLS:

Torque wrench (10 to 45 Nm)

Torque wrench (0.7 to 1.4 Nm)

No 1 Pozidriv

No 2 Pozidriv Socket 26mm Socket 20mm Socket 18mm (long reach)

Socket 16mm Socket 14mm Socket 13mm Socket 8mm (long reach)

Various socket adaptors to mate up with torque wrenches

Long nose pliers

Sharp knife

SPECIAL TOOLS:

Available as a tool kit, reference OEM Part #219287 for Prestige Classic 210006.

M5 nut runner

Air bleed push fix

Potentiometer trimmer (flat bladed jewellers screwdriver).

Pressure indicator driver

TEST EQUIPMENT:

Continuity tester

Temperature probe (3mm o/d)

Temperature recorder/ indicator

N.B Ensure all your test equipment has a current calibration certificate.